

MANUAL DEL UTILIZADOR

USER MANUAL

CE -R 404

MODELOS

MODELOS COMPACTOS / UNDERCOUNTER MODELS

SPIKA NG 60 **104.166**

SPIKA NG 90

SPIKA NG 110

SPIKA NG 140

MODELOS MODULARES / MODULAR MODELS

SPIKA MS 220

SPIKA MS 410

ESPAÑOL

ENGLISH

FRANÇAIS

DEUTSCH

PORTUGUÊS

ITALIANO

ΕΛΛΗΝΙΚΑ

DANSK

NEDERLANDS

SVENSKA

BOKMÅL

POLSKI

РУССКИЙ

한국어

MANUAL DEL UTILIZADOR
USER MANUAL

INTRODUCTION

Thank you for purchasing a 'Spika Series' Ice Cube Maker by ITV. You have purchased one of the most reliable ice-making products on the market today.

Carefully read the instructions contained in this manual since they provide important information relative to safety during installation, use, and maintenance.

WARNING

The installation of this equipment should be done by the Service Department.

The socket should always be placed on an accessible location.

Always disconnect the power supply from the machine before any cleaning or maintenance service.

Any change needed on the electrical installation for the appropriate connection of the machine, should be exclusively performed by qualified and certified professional personnel only.

Any use by the ice maker not intended to produce ice, using potable water, is considered inappropriate.

It is extremely dangerous to modify or intend to modify this machine, and will void warranty.

This machine should not be used by children or handicapped without the proper supervision and monitoring.

This machine is not intended to be used outdoors nor exposed to the rain.

It is mandatory to ground the equipment to avoid possible electric shock on individuals or damages to the equipment. The machine should be grounded pursuant local and/or national regulations as the case may be. The manufacturer shall be held harmless in case of damages arising due to the lack of the ground installation.

In order to assure the proper operation and efficiency of this equipment, it is of paramount importance to follow the recommendations of the manufacturer, especially those related to cleaning and maintenance operations, which should be performed by qualified personnel only.

CAUTION: The intervention of non-qualified personnel, besides of being dangerous, could result in serious malfunctioning. In case of damages, contact your distributor. We recommend always using original spare parts.

ITV reserves the right to make changes in specifications and design without prior notice.

RECEPTION OF THE MACHINE

Inspect the outside packing. In case of damages, **MAKE THE CORRESPONDING CLAIM TO THE CARRIER.** To confirm the existence of damages, **UNPACK THE MACHINE IN THE PRESENCE OF THE CARRIER** and state any damage on the equipment on the reception document or freight document.

Always state the machine number and model. This number is printed on three locations:

(1) Packing: On the outside, it contains a label with the manufacturing number.



(2) Exterior of the equipment: On the back of the equipment, there appears a label with the same characteristics as the previous one.

(3) Nameplate: On the back of the machine.

ITV		N:1161955		
MODELO: SPIKA NG 60-A1F				
V. 220-240	Hz. 50	A. 3	⇌ A. 10	W. 350
REF. R404 250 gr.	CE	CONDENSACION - CONDENSATION - KONDENSATION AIRE - AIR - LUFT		CLASE T

Check that in interior of the machine the installation kit is complete and comprises:

- Scoop, drain hose, four legs and manual.
- Warranty and serial number.
- Water connection.

CAUTION: All packing elements (plastic bags, carton boxes and wood pallets) should be kept outside the reach of children, as they are a source of potential hazard.

INSTALLATION

I. LOCATION OF ICE MACHINE

This ice maker is **not** designed for outdoor operation. The icemaker should not be located next to ovens, grills or other high heat producing equipment.

The SPIKA machines are designed to operate at room temperature between 5°C (41°F) and 43°C (109.4°F). There may be some difficulties in ice slab removal under the minimum temperatures. Above the maximum temperature, the life of the compressor is shortened and the production is substantially lower.

The air cooled SPIKA NG (undercounter) ice makers take the air through the front section, and drive it off through the lateral, back and also front louvers due to their new oblique condenser structure and placement. Do not place anything on the top of ice maker or facing the front grille. In case the front grille is either total or partially obstructed, or due to its placement it receives hot air from another device, we recommend, in case it is not possible to change the location, to install a water cooled machine.

The air cooled SPIKA MS (modular) ice makers take the air through the back section and drive it off through the two lateral louvers. In the case it is not possible to respect the minimum distances recommended (see the picture in point 3) for these machines we recommend to install a water cooled unit.

The location must allow enough clearance for water, drain and electrical connections in the rear of the ice machine. It is important that the water inlet piping do not pass near sources of heat so as not to lose ice production.

2. LEVELING THE ICE MACHINE

Use a level on top of ice machine in order to ensure the equipment is perfectly leveled.

Only for SPIKA NG (undercounter) machines:

Screw the leveling legs onto the bottom of the ice machine as far as possible.

Move the machine into its final position.

Use a level on top of the ice machine. Turn each foot as necessary to level the ice machine from front to back and side to side.

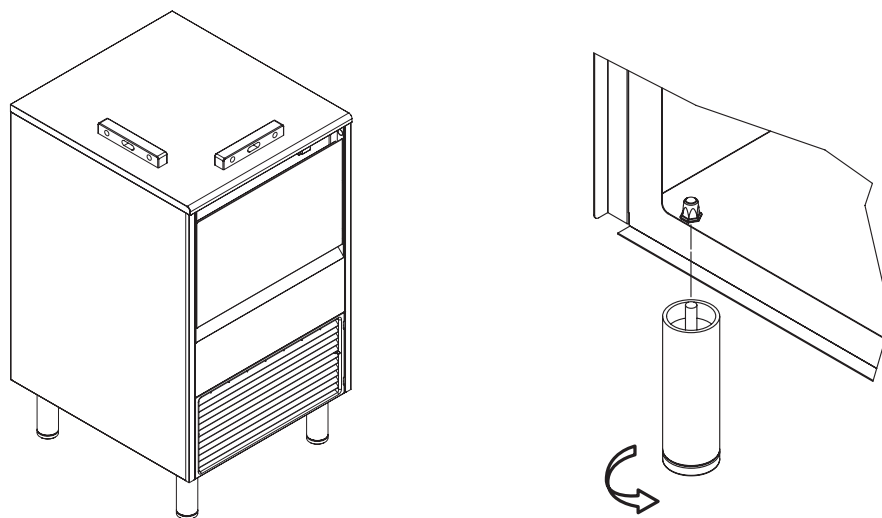

3. MINIMUM DISTANCE TO OBSTACLES

The minimum clearance values you can see below are recommended for efficient operation and servicing.

UNDERCOUNTER MODELS

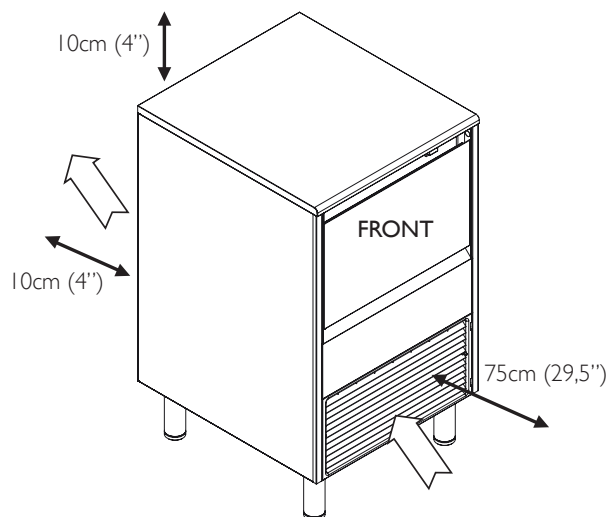

MODULAR MODELS

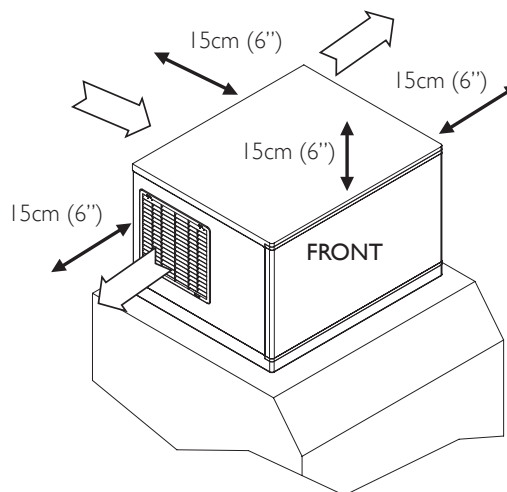

4. CONNECTION DIAGRAM

The location must allow enough clearance for water drain and electrical connections in the rear of the ice machine.

UNDERCOUNTER MODELS

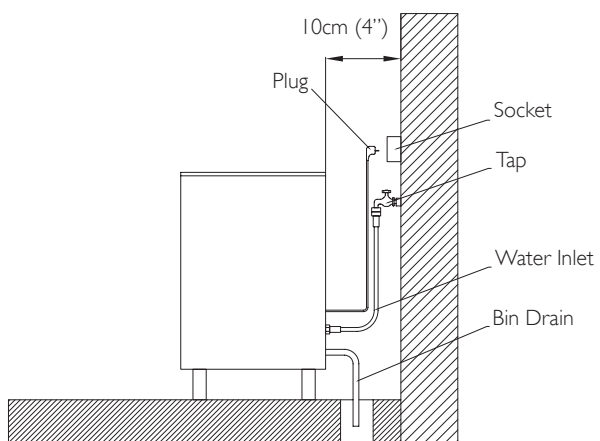

MODULAR MODELS

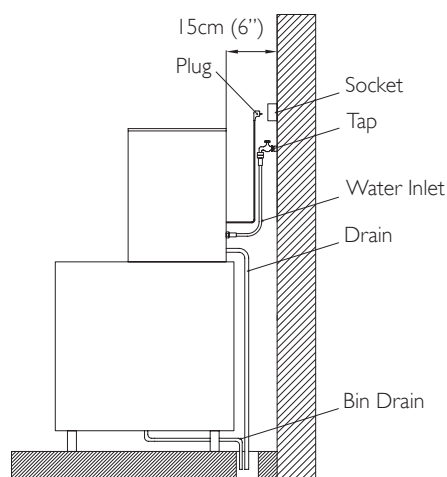

5. WATER SUPPLY

The quality of the water supplied to the ice machine will have an impact on the time between cleanings and ultimately on the life of the product (mainly in water cooled units). It also will have a remarkable influence on the appearance, hardness and flavor of the ice.

Local water conditions may require treatment of the water to inhibit scale formation, improve taste and clarity. If you are installing a water filter system, refer to the installation instructions supplied with the filter system. Pressure should be between 10 and 85 psi (0.7 and 6 bar). If pressure overpasses such values, install a pressure regulator.

ATTENTION: The machine shall be plumbed.

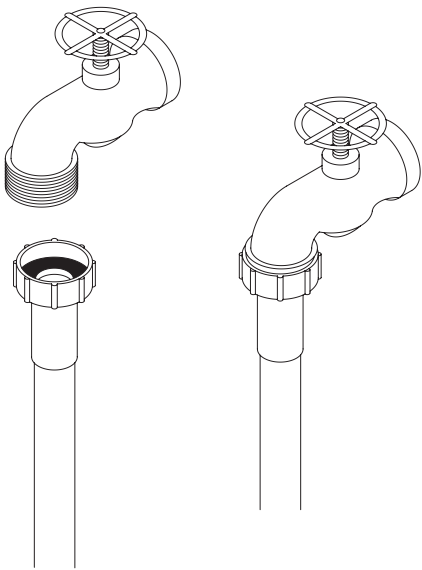

6. DRAINAGE

Drainage should be located below the level of the machine, at 5,9" (150 mm) minimum.

It is convenient that the drainage pipe is 30 mm (1.18") inside diameter and with a minimum gradient of 3 cm/meter (0.36"/ft), see figure.

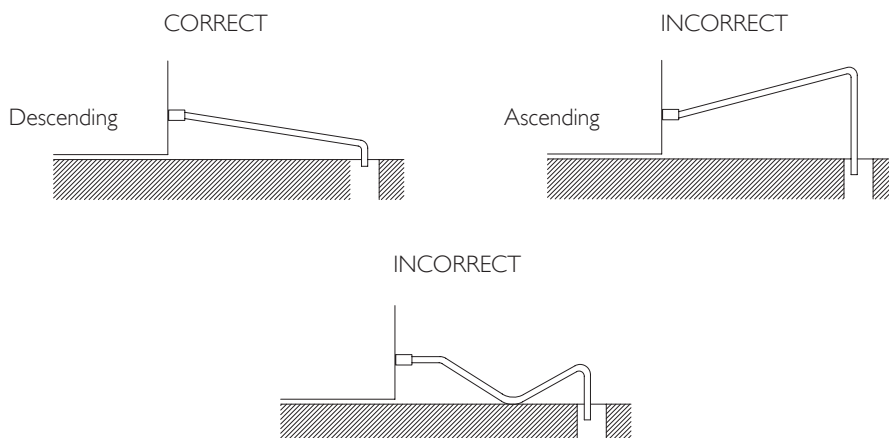

7. ELECTRICAL CONNECTION

It is mandatory to ground the equipment: to avoid possible discharges on individuals or damages to the equipment, the machine should be grounded pursuant local and/or national regulations as the case may be.

The manufacturer shall be held harmless in case of damages arising due to the lack of the ground installation.

In case the supply cable is damaged, it should be replaced by a cable of special assembly to be furnished by the manufacturer or after-sales service. Such replacement should be performed by qualified technical service only.

The machine should be placed in such a way as to allow a minimum space between the back and the wall to allow an easy access and without risks to the cable plug.

Safeguard the socket. It is convenient to install adequate switches and fuses.

Voltage is indicated in the nameplate and on the technical specifications of this manual. **Variation on voltage above the 10% stated on the nameplate could result on damages or prevent the machine start-up.**

MODELS	VOLTAGE FREQUENCY PHASE	TOTAL AMPS	FUSE
		(A)	(A)
SPIKA NG 60	220V / 50Hz / 1Ph	3	16
SPIKA NG 90	220V / 50Hz / 1Ph	3,5	16
SPIKA NG 110	220V / 50Hz / 1Ph	5	16
SPIKA NG 140	220V / 50Hz / 1Ph	5,5	16
SPIKA NG 220	220V / 50Hz / 1Ph	7	16
SPIKA MS 410	380-440V / 50Hz / 3Ph	4,2	16
SPIKA MS 410	208-230V / 60Hz / 3Ph	5,8	16

8. INSTALLATION OF MODULAR EQUIPMENTS ON TOP OF BINS

Modular ice makers should be installed on top of bins, following the instructions contained in this manual.

The resistance and stability of the container-machine/s assembly should be verified, as well as the fastening elements.

Follow bin manufacturer instructions.

START-UP

(I) Previous Checkup

- Is the machine leveled?
- Voltage and frequency are the same as those on the nameplate?
- Are the discharges connected and operating?
- Will the ambient temperature and water temperature remain in the following range?

	ROOM	WATER
MAXIMUM	43° C / 109° F	35° C / 95° F
MINIMUM	5° C / 41° F	5° C / 41° F

- Is water pressure appropriate?

MINIMO	0.7 Bar (10 psig)
MAXIMO	6 Bar (85 psig)

NOTE: In case input water pressure is higher than 85 psi (6 bar), install a pressure regulator.

For undercounter machines:

In case the room temperature exceeds 29.5°C (85°F) or water inlet temperature exceeds 20°C (68°F) the following adjustments should be made to ensure a proper efficiency.

The wheel G1 should have 2 more pins than G2, one by each side of those from the other.

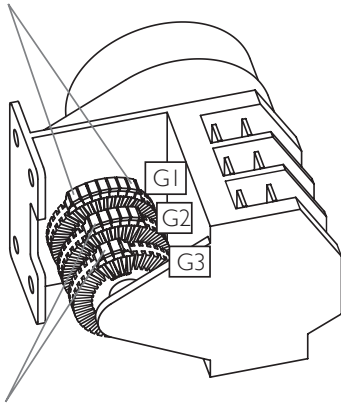

The first pin in G2 and G3 wheels must coincide in their position.

	Air temp >29.5°C (85°F) Water temp > 20°C (68°F)			Air temp <29.5°C (85°F) Water temp <20°C (68°F)		
	G1	G2	G3	G1	G2	G3
SPIKA NG 125	6	4	2	12	10	5
SPIKA NG 175	9	7	3	12	10	5
SPIKA NG 215	9	7	3	12	10	5
SPIKA NG 285	9	7	3	12	10	5

Indicating the number of white pins

(2) Start-Up

Once the installation instructions are followed (ventilation, site conditions, temperatures, water quality, etc.), proceed as follows:

- 1) Open the water inlet. Verify the no existence of leakages.
- 2) For undercounter models open the door and remove the protection elements on the shield. For modular models remove the two locking screws on top of machine, take off the front panel and remove protection elements on the shield and also on the thickness sensor.
- 3) Verify that the shield moves freely. For modular models verify also the thickness sensor moves freely.
- 4) Connect the machine to the power supply.
- 5) For undercounter models: push the blue switch on the machine front side. For modular models: push the blue switch found on the back of the machine and then set the ice-wash switch to the position I.
- 6) Verify that there are no vibrations or frictions on the elements.
- 7) Verify that the water fall to the evaporator is occurring uniformly and all ice cubes are properly watered.
- 8) Close door (for undercounter models) / Replace the front panel in its place (for modular models).
- 9) Verify that after the final cycle, the frost on the aspiration pipe is at 20 mm (0.78 in) of the compressor.
- 10) For modular models: Verify the ice slab with the pictures below. In case the thickness sensor needs to be regulated, rotate the thickness adjustment screw CW to increase bridge thickness. Rotate CCW to decrease bridge thickness.

For undercounter models adjust the cycle thermostat.

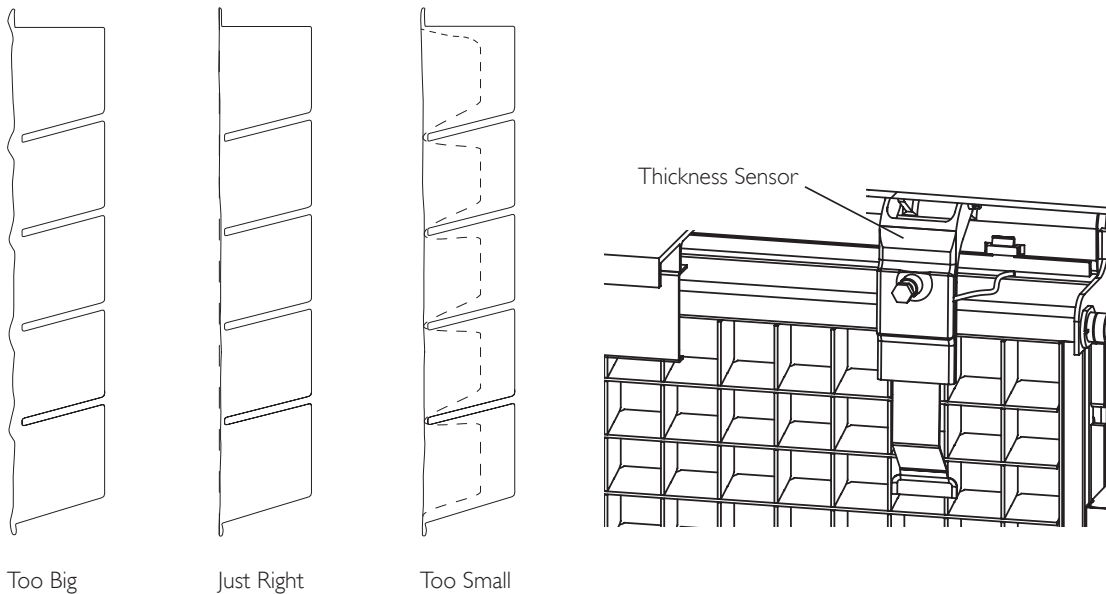

Damages due to the lack of maintenance and cleaning operations are not included on the warranty.

(3) Sequence of Operation

FOR UNDERCOUNTER MODELS:

Initial Start-up: It's recommended that the first time the machine is started (or the water tray has been emptied) it begins with the harvest sequence to ensure the water tray is filled.

Freeze sequence: The compressor is energized. The micro G2 de-energizes the hot gas valve, so the evaporator begins to freeze. The micro G2 energizes the water pump so the water circulates from the water tray to the upper distributor, flowing through each cube cell, where it freezes.

Harvest sequence: The compressor will continue energized. The micro G2 energizes the hot gas valve during a certain time. The micro G3 at the same time energizes the water inlet valve during a certain time to fill the water tray with the appropriate quantity of water. The ice slab slides off the evaporator and into the bin. After this, the freeze sequence starts again.

When storage bin is full the stock thermostat detects a low temperature and the machine shuts off at the end of the freeze sequence. The ice machine remains off until enough ice has been removed from the storage bin and the stock thermostat doesn't detect this low temperature.

FOR MODULAR MODELS:

Initial Start-up: The pump and the drain electrovalve are energized during 30 seconds to empty the water tray preventing the scale build-up in water. Then the pump and the drain electrovalve are de-energized, and the water inlet valve is energized filling the water tray until the water level sensor detects the water reaches the appropriate level. Then the freeze sequence starts.

Freeze sequence: The compressor is energized and the water pump is energized after 30 seconds. The water inlet valve is also energized at the same time that the water pump to replenish water level and then de-energized. The compressor and water pump will continue energized until the thickness sensor detects the thickness of the ice slab is the appropriate. Then the harvest sequence starts.

Harvest sequence: The compressor will continue energized. The hot gas valve is energized throughout the harvest phase to divert hot refrigerant gas into the evaporator. The water pump and the drain electrovalve are energized during 45 seconds to empty the water tray and remove mineral deposits. After this (water pump and drain electrovalve de-energized) the water inlet valve is energized filling the water tray until the water level sensor detects water reaches the level. The ice slab slides off the evaporator and into the bin. The momentary opening and re-closing of the shield indicates the harvest sequence has finished and goes to the freeze sequence.

When the storage bin is full, the ice shield is held open during more than 30 seconds and the machine shuts off. The ice machine remains off until enough ice has been removed from the storage bin to allow the ice shield swings back to the operating position

MAINTENANCE AND CLEANING PROCEDURES

It is the User's responsibility to keep the ice machine and ice storage bin in a sanitary condition. Ice machines also require occasional cleaning of their water systems with a specifically designed chemical. This chemical dissolves mineral build up that forms during the ice making process.

Sanitize the ice storage bin as frequently as local health codes require, and every time the ice machine is cleaned and sanitized.

The ice machine's water system should be cleaned and sanitized at least twice a year.

CAUTION: Do not mix Ice Machine Cleaner and Sanitizer solutions together.

WARNING: Wear rubber gloves and safety goggles when handling Ice Machine Cleaner or Sanitizer.

WARNING: Unit should always be disconnected during maintenance/cleaning procedures.

CLEANING WATER DISTRIBUTION SYSTEM

(I) Cleaning Water Distribution System for Undercounter Models

- 1) Set the switch to the OFF position after ice falls from the evaporator at the end of a harvest cycle, or set the switch to the OFF position and allow the ice to melt off the evaporator.

CAUTION: Never use anything to force ice from the evaporator.

- 2) Remove the back metal lid and the top panel (if it need be to make easier the cleaning operations).

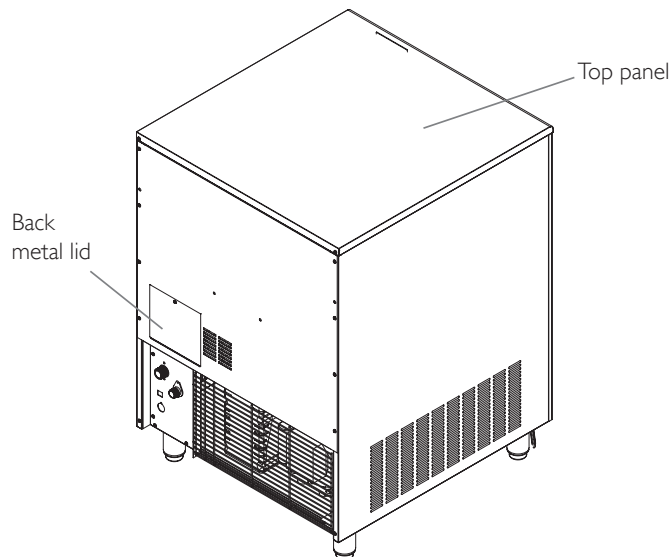

- 3) Remove all ice from the bin.
- 4) Remove the auxiliary pipe for drain operations near the pump and empty the water tray. Return it to their original position to avoid water spill.

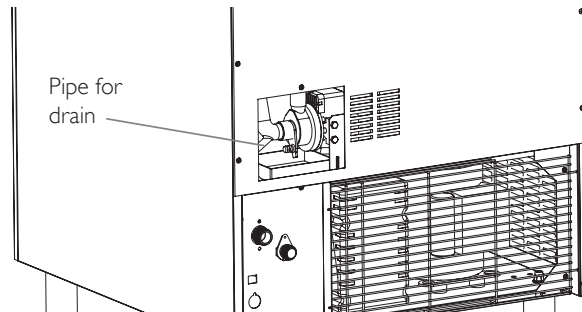

- 5) Prepare a solution of an appropriate product for the cleaning of ice machines (lime). Do not use hydrochloric acid. We recommend the use of any NSF approved scale removal product prepared according to the manufacturer's instructions.
- 6) Fill water tray with the solution.

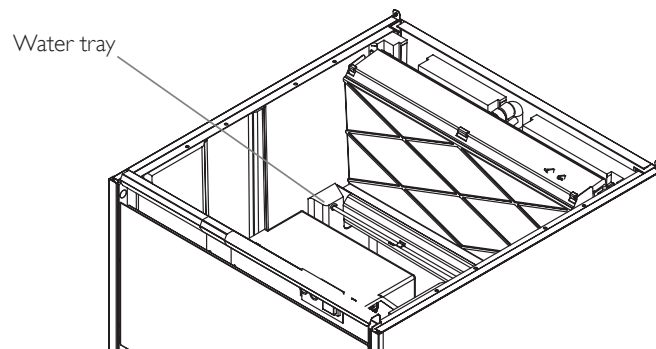

- 7) Switch compressor switch (see figure below) to position 0, and switch on machine in order to run water pump. Let solution stand for 30-40 minutes and then switch off the machine.

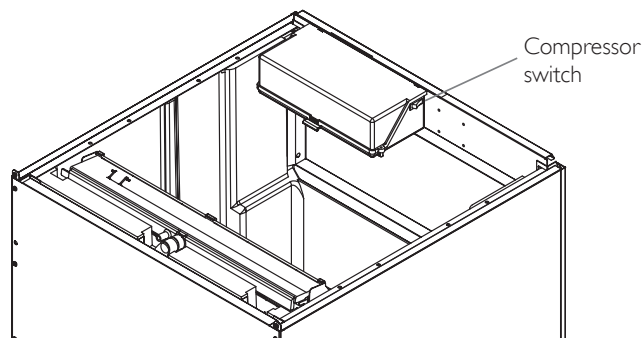

- 8) Disconnect power and water supplies.
- 9) Remove the auxiliary pipe to drain and purge out the ice machine scale remover and residue. Replace it.
- 10) Mix enough cleaning solution (as in point 5) to clean parts and interior food zone surfaces.
- 11) Remove shield.

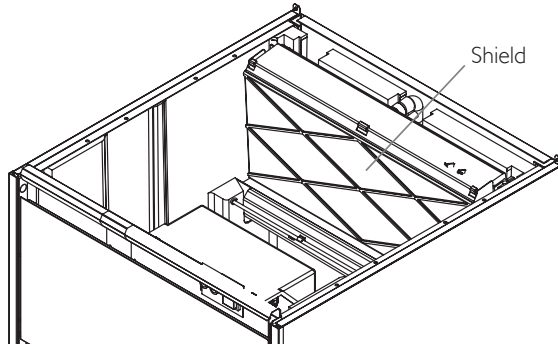

- 12) Clean all surfaces of the shield with the cleaner solution using a brush (not a wire brush) or cloth. Rinse all areas with water.
- 13) Clean all the interior surfaces of the freezing compartment (including storage bin) with the cleaner solution using a brush or cloth. Rinse all areas with water.
- 14) Mix a solution of sanitizer using approved (EPA/FDA) sodium hypochlorite food equipment sanitizer to form a solution with 100 - 200 ppm free chlorine yield.
- 15) Sanitize all surfaces of the shield applying liberally the sanitizer solution using a cloth or sponge.
- 16) Sanitize all the interior surfaces of the freezing compartment (including the storage bin) applying liberally sanitizer solution, using a cloth or sponge.
- 17) Return shield to its position.
- 18) Connect power and water supplies.
- 19) Fill water reservoir with the sanitizer solution.
- 20) Switch on machine in order to run water pump. Let solution stand for 20 minutes and switch off.
- 21) Remove the auxiliary pipe to drain and purge out the sanitizer solution and residue. Replace it. Fill the water reservoir with water and switch on the machine to allow water to circulate for 5 minutes and then stop the machine. Repeat this operation two more times to rinse thoroughly.
- 22) Remove the auxiliary hose to drain the water. Replace it and fill the tray with water to ensure the pump works properly.
- 23) Switch on compressor switch (position I).
- 24) Return the back metal lid and the top panel to their position.
- 25) Switch on machine and discard the first two harvests.

(2) Cleaning Water Distribution System for Modular Models

- 1) Set Ice-wash switch to the OFF position (position 0) after ice falls from the evaporator at the end of a harvest cycle, or set the ice-wash switch to the OFF position and allow the ice to melt off the evaporator.
CAUTION: Never use anything to force ice from the evaporator. Damage may result.

- 2) Remove the front panel.

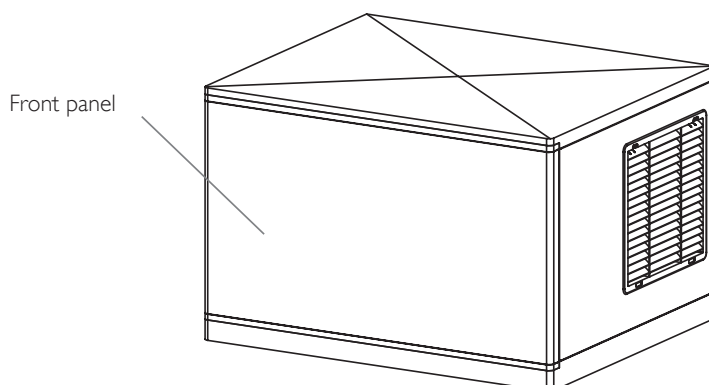

- 3) Prepare a solution of an appropriate product for the cleaning of ice machines (lime). Do not use hydrochloric acid. We recommend the use of any NSF approved scale removal product. In modular machines the water bucket is filled automatically so we recommend to prepare a previous solution (for example 0.15 l) according to the manufacturer's instructions with the total quantity of product needed for the water tray (0.3 l for MS 440 and 6 l for MS 880).
- 4) To start a cleaning cycle, move the ice-wash switch to the WASH position (position II). The machine will drain the reservoir and refill it. Pour the scale remover solution into the reservoir.

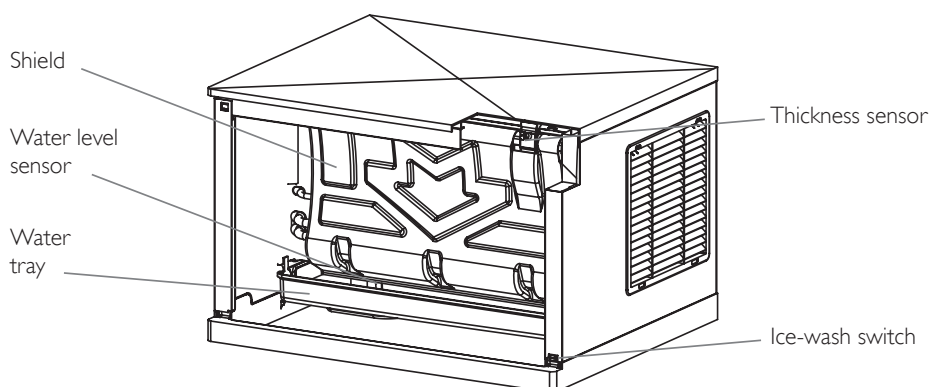

- 5) Allow the solution to circulate in the water system for 30-40 minutes and then set the ice-wash switch to the OFF position.
- 6) To purge out the ice machine scale remover and residue move the ice-wash switch to the WASH (the machine will drain the reservoir and refill it) and then set the ice-wash switch to the OFF position.
- 7) Disconnect power and water supplies.
- 8) Mix a cleaning solution.
- 9) Remove shield and water tray.

- 10) Clean the metal surfaces of the thickness sensor, water level sensor, the adjustment screw, the shield and the water tray with the cleaner solution using a brush (not a wire brush) or cloth.

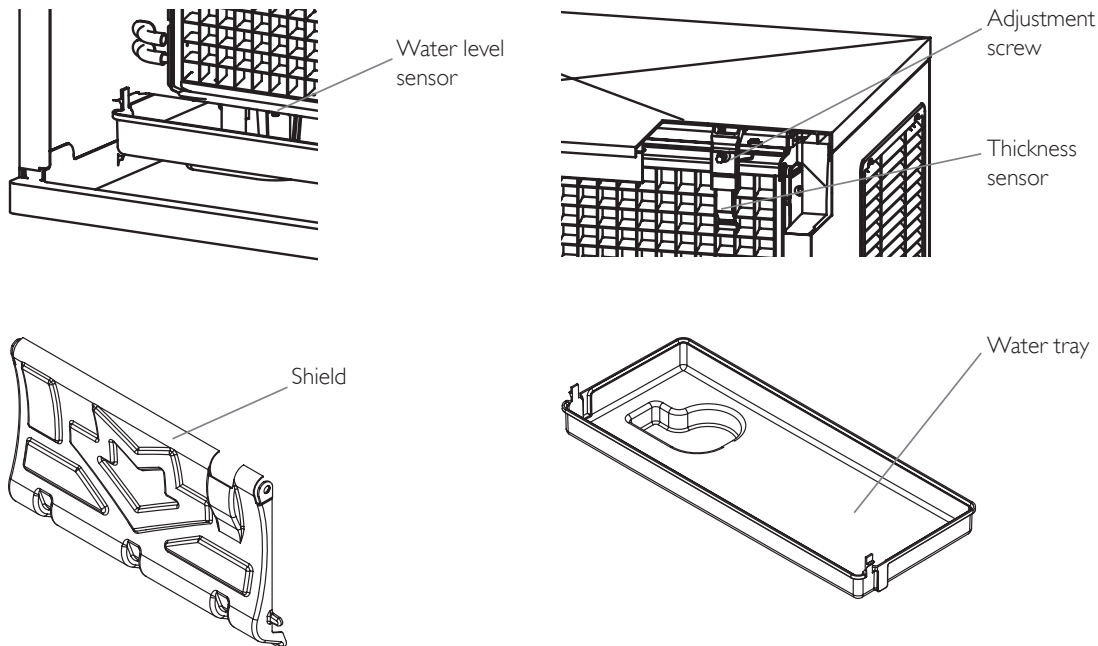

- 11) Clean the interior surfaces of the freezing compartment (including walls, plastic parts of the evaporator, distributor...) and the front panel with the cleaner solution using a brush or cloth.
- 12) Mix a solution of sanitizer using approved (EPA/FDA) sodium hypochlorite food equipment sanitizer to form a solution with 100 t 200 ppm free chlorine yield.
- 13) Sanitize all surfaces of the ice thickness sensor, water level sensor, shield and water tray applying liberally the sanitizer solution using a cloth or sponge.
- 14) Sanitize the interior surfaces of the freezing compartment (including walls, plastic parts of the evaporator, distributor...) and the front panel applying liberally the sanitizer solution using a cloth or sponge.
- 15) Return the water tray and shield to their normal positions.
- 16) Connect power and water supplies.
- 17) To start a sanitation cleaning cycle, move the ice-wash switch to the WASH position. The machine will drain the reservoir and refill it. Pour the sanitizer into the water reservoir to get a solution as in the point 12 (the volume in the water tray is approximately 6 l for MS 880 and 3 l for MS 440).
- 18) Allow the solution to circulate in the water system for 20 minutes and then set the ice-wash switch to the OFF position.
- 19) To purge out the sanitizer solution and residue move the ice-wash switch to the WASH position (drain and refill) and allow the water to circulate for 5 minutes and then move the switch to the OFF position (drain). Repeat this operation two more times to rinse thoroughly.
- 20) Return the panel to their position.
- 21) Set the ice-wash switch to the ON position (position I) and discard the first two harvests.

CLEANING THE ICE BIN (FOR UNDERCOUNTER MODELS)

- 1) Disconnect the machine, close water faucet and empty storage bin of ice
- 2) Use the cleaner/water solution to clean all surfaces of the bin. Use a nylon brush or cloth. Then rinse all areas thoroughly with clean water.
- 3) Use the sanitizer/water solution to sanitize all surfaces of the bin. Use a nylon brush or cloth.
- 4) Rinse with plenty of water, dry, run the machine and open water faucet.

CLEANING THE CONDENSER

(1) Air Condenser

- 1) Disconnect machine and close water faucet.
- 2) For undercounter models remove the front grid by pressing the two clips placed at right side (see figure).

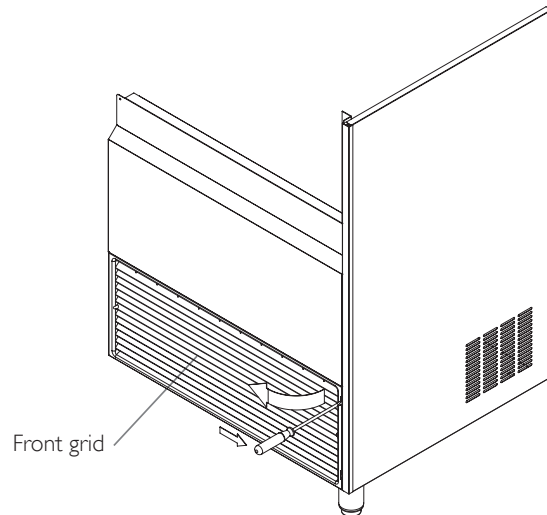

For modular models remove the back panel (see figure).

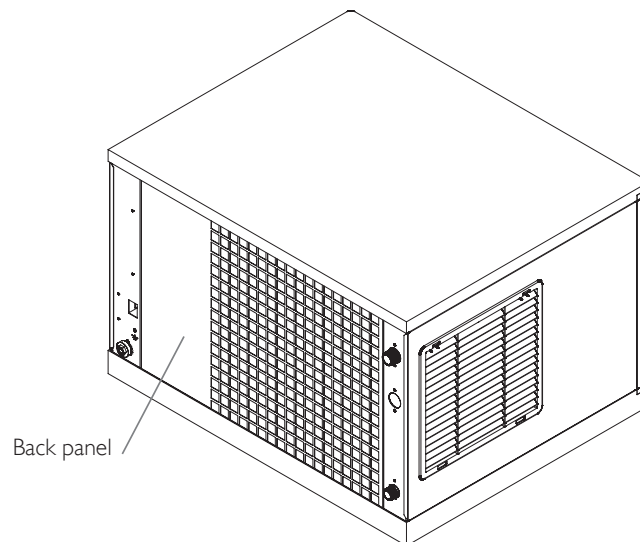

- 3) Clean condenser using a vacuum cleaner, soft brush or low pressure air. Clean from top to bottom, not side to side.
Be careful not to bend the condenser fins.

(2) Water Condenser

The water condenser may require cleaning due to scale build-up. The cleaning procedures require special pumps and cleaning solutions. They must be performed by qualified maintenance or service personnel.

CLEANING THE OUTSIDE OF THE MACHINE

Clean the area around the ice machine as often as necessary to maintain cleanliness. Sponge any dust and dirt off the outside of the ice machine with mild soap and water. Wipe dry with a clean soft cloth. A commercial grade stainless steel cleaner/polish can be used as necessary.

CHECKING FOR WATER LEAKS

This must be done whenever maintenance is carried out on the machine: check all water connexions, braces, tubes and hoses in order to eliminate leaks and prevent breakages and flooding.

USER TROUBLESHOOTING GUIDE

UNDERCOUNTER MODELS:

PROBLEM	PROBABLE CAUSE	SOLUTION
None of the electrical parts work.	The machine is unplugged.	Plug in the machine and verify socket power.
	Bin thermostat open. Ice touching bin tube.	Remove ice from the bin.
	Bin thermostat open. No ice touching bin tube.	Adjust thermostat (electric box under top cover).
All the electrical parts work but not compressor. (water doesn't get frozen).	Compressor switch is in the "WASH" position (0).	Switch to "ICE" position (1).
No water in tray.	Not incoming water.	Check water supply.
	Inlet strain at water valve blocked.	Check and clean.
Bin full and ice touching thermostat tube, but machine doesn't stop.	Bin thermostat doesn't open (only operates at harvest time).	Adjust thermostat (electric box under top cover).
Ice slab empty or too thick.	Desadjusted cycle time.	Adjust thermostat (electric box under top cover).
Difficult to release ice slab at harvest.	Unit bad leveled (tilted to back).	Level; down front.
	Not enough harvest time.	Add more pins to cam timer wheels (as label indications).
Not uniform flow pattern at evaporator.	Dirty or scaled distributor.	Perform descaling procedure. Remove and clean distributor (pull from two clips at distributor sides).
Unit run and stops alternatively itself	Safety presostat opens.	Clean air condenser (behind front grid).
For further problems call aftersales service.		

MODULAR MODELS:

PROBLEM	PROBABLE CAUSE	SOLUTION
None of the electrical parts work.	The machine is unplugged.	Plug in the machine and verify socket power.
	Rear switch OFF.	Switch ON.
	Front switch position "0".	Move to "ICE" (behind front panel).
All the electrical parts work but not compressor. (water doesn't get frozen).	Front switch position "WASH".	Move to "ICE" (behind front panel).
No water in tray.	Not incoming water.	Check water supply.
	Inlet strain at water valve blocked.	Check and clean.
Not enough water to end cycle.	Water level probe too low.	Move up (steel rod beside pump).
	Defective drain valve (check drain leak during ice stage).	Disassemble and clean.
	Shield splash leaks.	Check shield position.
Water overflows tray.	Level probe too high or scaled.	Adjust / clean.
Ice slab empty or too thick.	Desadjusted/scaled thickness probe.	Adjust / clean.
Difficult to release ice slab at harvest.	Unit badly leveled (tilted to back).	Level; down front.
Not uniform flow pattern at evaporator.	Dirty or scaled distributor.	Perform descaling procedure. Remove and clean distributor (pull from two clips at distributor sides).
Low production.	Dirty condenser.	Clean (check also incoming water/air temperature).
Unit stops after few time running.	Safety presostat opens.	Clean air condenser (back).
For further problems call aftersales service.		

ELECTRICAL DIAGRAMS

SPIKA NG (UNDERCOUNTER MODELS)

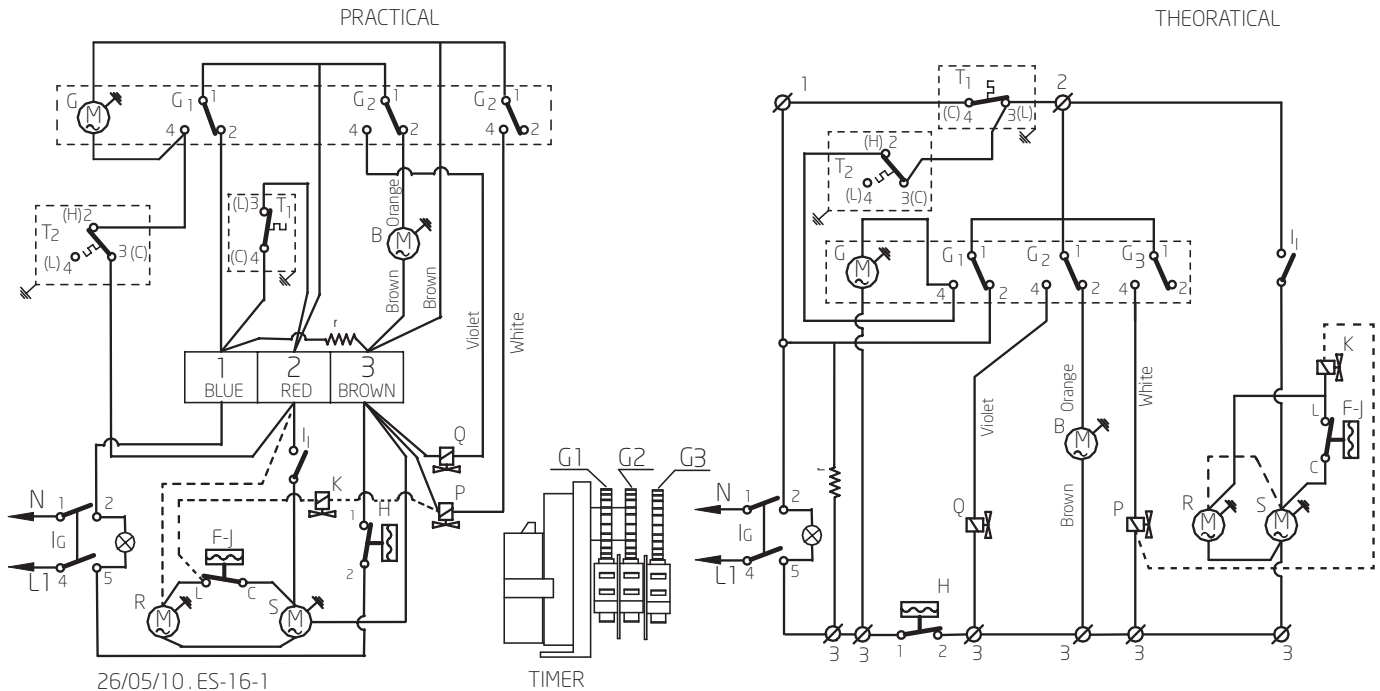

COMPONENTS

- B Motor pump
- F Fan pressostat (air)
- G Cam timer motor
- G1 Circuit safety timer
- G2 Circuit timer
- G3 Circuit timer (water inlet valve)
- H Safety pressostat
- J Condensing pressostat (water)
- K Condensing electrovalve (water)
- P Water inlet valve
- Q Hot gas electrovalve
- R Fan motor
- S Compressor
- T1 Stock thermostat
- T2 Cycle thermostat
- Ig ON/OFF Switch
- I1 Cleaning switch
- for water condenser

SPIKA MS (MODULAR MODELS)

(I) WIRING DIAGRAM, ONE PHASE.

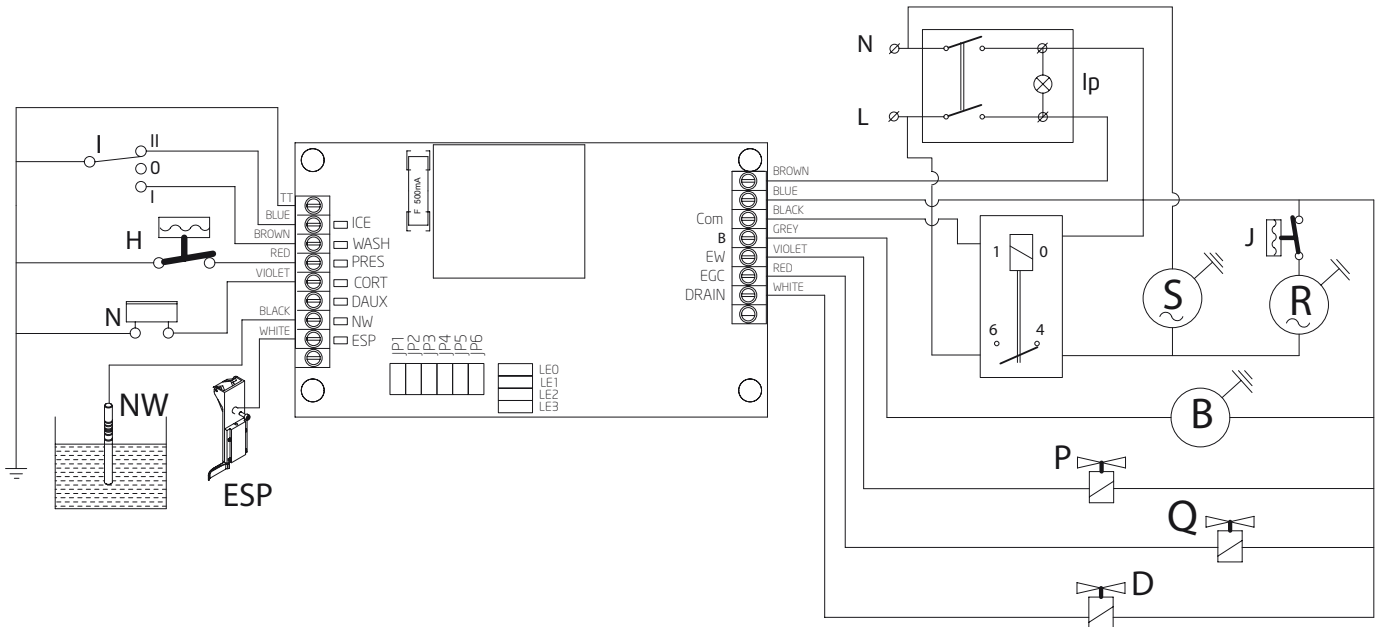

COMPONENTS

- H Safety pressostat
- N Shield switch
- I Ice-wash switch (3 positions)
- S Compressor
- R Fan motor
- J Condensing pressostat (only air).
- B Pump motor
- P Water inlet valve
- Q Hot gas valve
- D Drain electrovalve
- NW Water level sensor
- ESP Thickness sensor
- Ip ON/OFF switch

(2) WIRING DIAGRAM, THREE PHASES.

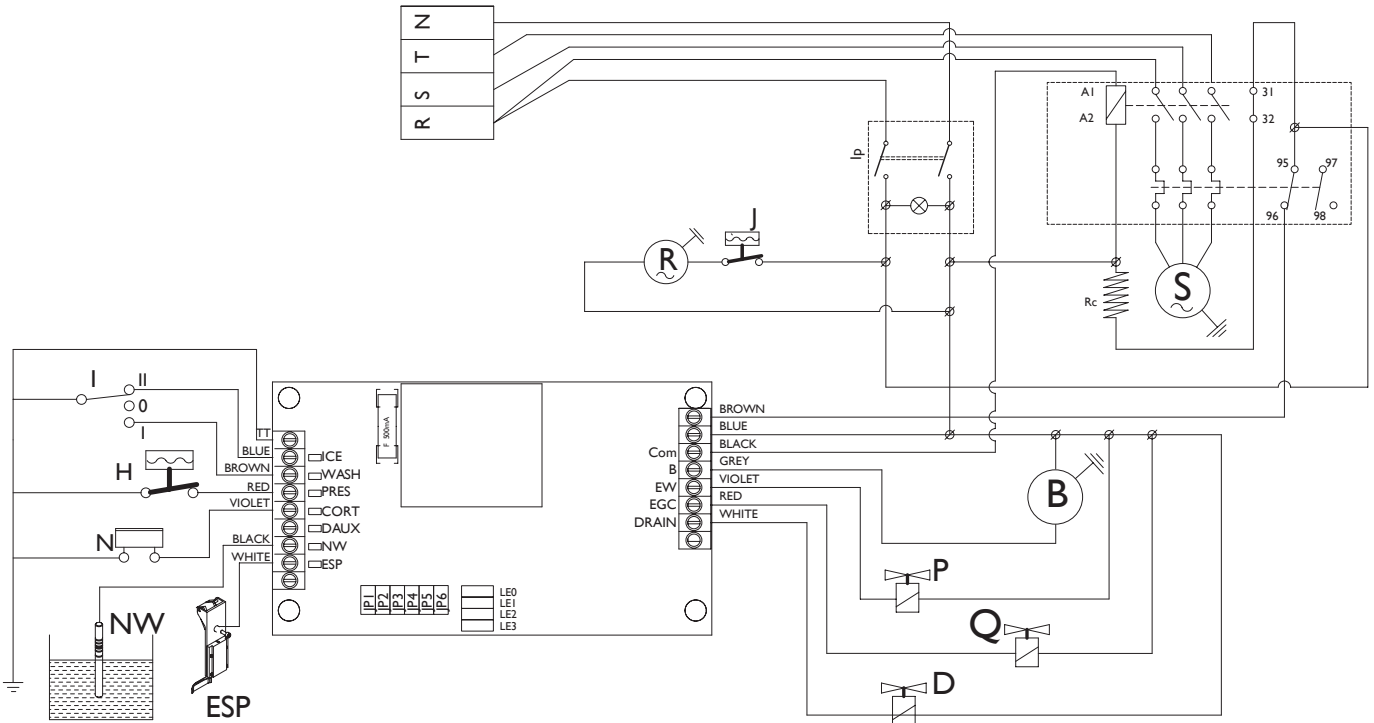

COMPONENTS

- H Safety pressostat
- N Shield switch
- I Ice-wash switch (3 positions)
- S Compressor
- R Fan motor
- J Condensing pressostat (only air)
- B Pump motor
- P Water inlet valve
- Q Hot gas valve
- D Drain electrovalve
- NW Water level sensor
- ESP Thickness sensor

D In Übereinstimmung mit den Anforderungen der Europäischen Richtlinie 2002/96/EG über Elektro- und Elektronik-Altgeräte (WEEE) ist vorliegendes Gerät mit einer Markierung versehen. Sie leisten einen positiven Beitrag für den Schutz der Umwelt und die Gesundheit des Menschen, wenn Sie dieses Gerät einer gesonderten Abfallsammlung zuführen. Im unsortierten Siedlungsmüll könnte ein solches Gerät durch unsachgemäße Entsorgung negative Konsequenzen nach sich ziehen. Auf dem Produkt oder der beiliegenden Produktdokumentation ist

folgendes Symbol  einer durchgestrichenen Abfalltonne abgebildet. Es weist darauf hin, dass eine Entsorgung im normalen Haushaltsabfall nicht zulässig ist. Entsorgen Sie dieses Produkt im Recyclinghof mit einer getrennten Sammlung für Elektro- und Elektronikgeräte.

Die Entsorgung muss gemäß den örtlichen Bestimmungen zur Abfallbeseitigung erfolgen. Bitte wenden Sie sich an die zuständigen Behörden Ihrer Gemeindeverwaltung, an den lokalen Recyclinghof für Haushaltsmüll oder an den Händler, bei dem Sie dieses Gerät erworben haben, um weitere Informationen über Behandlung, Verwertung und Wiederverwendung dieses Produkts zu erhalten.

GB This appliance is marked according to the European directive 2002/96/EC on Waste Electrical and Electronic Equipment (WEEE). By ensuring this product is disposed of correctly, you will help prevent potential negative consequences for the environment and human health, which could otherwise be caused by inappropriate waste handling of this product.

The symbol  on the product, or on the documents accompanying the product, indicates that this appliance may not be treated as household waste. Instead it shall be handed over to the applicable collection point for the recycling of electrical and electronic equipment.

Disposal must be carried out in accordance with local environmental regulations for waste disposal. For more detailed information about treatment, recovery and recycling of this product, please contact your local city office, your household waste disposal service or the shop where you purchased the product.

F Cet appareil porte le symbole du recyclage conformément à la Directive Européenne 2002/96/CE concernant les Déchets d'Équipements Électriques et Électroniques (DEEE ou WEEE). En procédant correctement à la mise au rebut de cet appareil, vous contribuerez à empêcher toute conséquence nuisible pour l'environnement et la santé de l'homme.

Le symbole  présent sur l'appareil ou sur la documentation qui l'accompagne indique que ce produit ne peut en aucun cas être traité comme déchet ménager. Il doit par conséquent être remis à un centre de collecte des déchets chargé du recyclage des équipements électriques et électroniques.

Pour la mise au rebut, respectez les normes relatives à l'élimination des déchets en vigueur dans le pays d'installation. Pour obtenir de plus amples détails au sujet du traitement, de la récupération et du recyclage de cet appareil, veuillez vous adresser au bureau compétent de votre commune, à la société de collecte des déchets ou directement à votre revendeur.

NL Dit apparaat is voorzien van het merkteken volgens de Europese richtlijn 2002/96/EG inzake Afgedankte elektrische en elektronische apparaten (AEEA). Door ervoor te zorgen dat dit product op de juiste manier als afval wordt verwerkt, helpt u mogelijk negatieve consequenties voor het milieu en de menselijke gezondheid te voorkomen die anders zouden kunnen worden veroorzaakt door onjuiste verwerking van dit product als afval.

Het symbool  op het product of op de bijbehorende documentatie geeft aan dat dit product niet als huishoudelijk afval mag worden behandeld. In plaats daarvan moet het worden afgegeven bij een verzamelpunt voor recycling van elektrische en elektronische apparaten.

Afdanking moet worden uitgevoerd in overeenstemming met de plaatselijke milieuvorschriften voor afvalverwerking. Voor nadere informatie over de behandeling, terugwinning en recycling van dit product wordt u verzocht contact op te nemen met het stadskantoor in uw woonplaats, uw afvalophalendienst of de winkel waar u het product heeft aangeschaft.

E Este aparato lleva el marcado CE en conformidad con la Directiva 2002/96/EC del Parlamento Europeo y del Consejo sobre residuos de aparatos eléctricos y electrónicos (RAEE). La correcta eliminación de este producto evita consecuencias negativas para el medioambiente y la salud.

El símbolo  en el producto o en los documentos que se incluyen con el producto, indica que no se puede tratar como residuo doméstico. Es necesario entregarlo en un punto de recogida para reciclar aparatos eléctricos y electrónicos. Deséchelo con arreglo a las normas medioambientales para eliminación de residuos.

Para obtener información más detallada sobre el tratamiento, recuperación y reciclaje de este producto, póngase en contacto con el ayuntamiento, con el servicio de eliminación de residuos urbanos o la tienda donde adquirió el producto.

P Este aparelho está classificado de acordo com a Directiva Europeia 2002/96/EC sobre Resíduos de equipamento eléctrico e electrónico (REEE).

Ao garantir a eliminação adequada deste produto, estará a ajudar a evitar potenciais consequências negativas para o ambiente e para a saúde pública, que poderiam derivar de um manuseamento de desperdícios inadequado deste produto.

O símbolo  no produto, ou nos documentos que acompanham o produto, indica que este aparelho não pode receber um tratamento semelhante ao de um desperdício doméstico.

Pelo contrário, deverá ser depositado no respectivo centro de recolha para a reciclagem de equipamento eléctrico e electrónico. A eliminação deverá ser efectuada em conformidade com as normas ambientais locais para a eliminação de desperdícios.

Para obter informações mais detalhadas sobre o tratamento, a recuperação e a reciclagem deste produto, contacte o Departamento na sua localidade, o seu serviço de eliminação de desperdícios domésticos ou a loja onde adquiriu o produto.

I Questo apparecchio è contrassegnato in conformità alla Direttiva Europea 2002/96/EC, Waste Electrical and Electronic Equipment (WEEE).

Assicurandosi che questo prodotto sia smaltito in modo corretto, l'utente contribuisce a prevenire le potenziali conseguenze negative per l'ambiente e la salute.

Il simbolo  sul prodotto o sulla documentazione di accompagnamento indica che questo prodotto non deve essere trattato come rifiuto domestico ma deve essere consegnato presso l'adeguato punto di raccolta per il riciclaggio di apparecchiature elettriche ed elettroniche.

Disfarsene seguendo le normative locali per lo smaltimento dei rifiuti. Per ulteriori informazioni sul trattamento, recupero e riciclaggio di questo prodotto, contattare l'adeguato ufficio locale, il servizio di raccolta dei rifiuti domestici o il negozio presso il quale il prodotto è stato acquistato.

GR Αυτή η συσκευή φέρει σημασία σύμφωνα με την Ευρωπαϊκή οδηγία 2002/96/ΕΕ σχετικά με Απορριπτόμενα Ηλεκτρικά και Ηλεκτρονικά Εξαρτήματα (WEEE).

Εξασφαλίζοντας ότι το προϊόν αυτό απορριπτείται σωστά, θα βοηθήσετε στην πρόληψη πιθανών αρνητικών επιπτώσεων για το περιβάλλον και την ανθρώπινη υγεία, οι οποίες θα μπορούσαν να δημιουργηθούν από τον ακατάλληλο χειρισμό αυτού του προϊόντος ως απόρριμμα.

Το σύμβολο  πάνω στο προϊόν, ή στα έγγραφα που συνοδεύουν το προϊόν, υποδεικνύει ότι αυτή η συσκευή δεν μπορεί να θεωρηθεί οικιακό απόρριμμα. Αντί γι αυτό θα πρέπει να παραδοθεί στο κατάλληλο σημείο περισυλλογής για την ανακύκλωση των ηλεκτρικών και ηλεκτρονικών εξαρτημάτων.

Διαλύστε το τηρώντας την τοπική νομοθεσία για τη διάθεση των απορριμμάτων. Για πιο λεπτομερείς πληροφορίες σχετικά με την επεξεργασία, την περισυλλογή και την ανακύκλωση αυτού του προϊόντος, παρακαλούμε επικοινωνήστε με το αρμόδιο γραφείο της τοπικής σας αυτοδιοίκησης, την τοπική σας υπηρεσία αποκομιδής οικιακών απορριμμάτων ή το κατάστημα όπου αγοράσατε αυτό το προϊόν.

S Denna produkt är märkt enligt EG-direktiv 2002/96/EEC beträffande elektriskt och elektroniskt avfall (Waste Electrical and Electronic Equipment, WEEE).

Genom att säkerställa en korrekt kassering av denna produkt bidrar du till att förhindra potentiella, negativa konsekvenser för vår miljö och vår hälsa, som annars kan bli följden om produkten inte hanteras på rätt sätt.

Symbolen  på produkten, eller i medföljande dokumentation, indikerar att denna produkt inte får behandlas som vanligt hushållsavfall. Den skall i stället lämnas in på en lämplig uppsamlingsplats för återvinning av elektrisk och elektronisk utrustning.

Produkten måste kasseras enligt lokala miljöbestämmelser för avfallshantering. För mer information om hantering, återvinning och återanvändning av denna produkt, var god kontakta de lokala myndigheterna, ortens sophanteringstjänst eller butiken där produkten inhandlades.

N Dette apparatet er mærket i samsvar med EU-direktiv 2002/96/EC om afhending av elektrisk og elektronisk udstyr (Waste Electrical and Electronic Equipment - WEEE). Forsikre deg om at dette produktet blir avhendet på korrekt vis, slik at det ikke kan utgjøre noen helse- eller miljørisiko.

Symbol  på produktet eller på dokumentene som følger med det, viser at dette produktet ikke må behandles som husholdningsavfall. Lever det til et autorisert mottak for resirkulering av elektrisk og elektronisk utstyr.

Avhending må skje iht. de lokale renovasjonsforskriftene. For nærmere informasjon om håndtering, kassering og resirkulering av dette produktet, kontakt kommunen, renovasjonsvesenet eller forretningen der du anskaffet det.

DK Dette produkt er mærket i henhold til EU-direktiv 2002/96/EF om Kasseret elektrisk og elektronisk udstyr (WEEE). Ved at sikre, at dette produkt bliver skrøttet korrekt, hjælper man med til at forhindre potentielle, negative konsekvenser for miljøet og folkesundheden, der kunne opstå gennem uhensigtsmæssig bortskaftelse af dette produkt.

Symbol  på produktet eller på dokumenterne, der ledsager produktet, angiver, at produktet ikke må bortskaftes sammen med husholdningsaffaldet. Det skal i stedet afleveres på en genbrugsstation for elektrisk og elektronisk udstyr.

Det skal skrøttes i henhold til gældende lokale miljøregler for bortskaftelse af affald. For yderligere oplysninger om håndtering, genvinding og genbrug af dette produkt bedes man kontakte de lokale myndigheder, renovationselskabet eller forretningen, hvor produktet er købt.

FIN Tämä laite on merkitty WEEE-direktiivin (Waste Electrical and Electronic Equipment) 2002/96/EC mukaisesti. Varmistamalla, että tuote poistetaan käytöstä asianmukaisesti, voidaan auttaa estämään sellaiset ympäristö- ja terveyshaitat, jotka saattaisivat aiheutua jätteiden asiattomasta käsittelystä.

Symboli  tuotteessa tai sen dokumentaatiossa tarkoittaa, ettei laitetta saa hävittää kotitalousjätteiden mukana. Sen sijaan tuote on toimitettava sähkö- ja elektroniikkakomponenttien keräys- ja kierrätyspisteeseen. Laitteen käytöstäpoiston suhteen on noudatettava paikallisia jätehuoltomääräyksiä.

Lisätietoja tuotteen käsittelystä, talteenotosta ja kierrätyksestä saa kaupungin- tai kunnanvirastosta, paikallisesta jätehuoltoilikkeestä tai liikkeestä, josta tuote ostettiin.

PL Niniejsze urządzenie posiada oznaczenia zgodnie z Dyrektywą Europejską 2002/96/EC w sprawie zużytego sprzętu elektrycznego i elektronicznego (WEEE). Zapewniając prawidłowe złomowanie niniejszego urządzenia przyczynią się Państwo do ograniczenia ryzyka wystąpienia negatywnego wpływu produktu na środowisko i zdrowie ludzi, które mogłoby zaistnieć w przypadku niewłaściwej utylizacji urządzenia.

Symbol  umieszczony na produkcie lub na dołączonych do niego dokumentach oznacza, że niniejszy produkt nie jest klasyfikowany jako odpad z gospodarstwa domowego.

Urządzenie, w celu jego złomowania, należy zdać w odpowiednim punkcie utylizacji odpadów w celu recyklingu komponentów elektrycznych i elektronicznych.

Urządzenie należy złomować zgodnie z lokalnymi przepisami dot. utylizacji odpadów.

Dodatkowe informacje na temat utylizacji, złomowania i recyklingu opisywanego urządzenia można uzyskać w lokalnym urzędzie miasta, w miejskim przedsiębiorstwie utylizacji odpadów lub w sklepie, w którym produkt został zakupiony.

CZ Tento spotřebič je označen v souladu s evropskou směrnicí 2002/96/ES o likvidaci elektrického a elektronického zařízení (WEEE). Zajištěním správné likvidace tohoto výrobku pomůžete zabránit případným negativním důsledkům na životní prostředí a lidské zdraví, ke kterým by nevhodnou likvidací tohoto výrobku mohlo dojít.

Symbol  na výrobku nebo na dokumentech přiložených k výrobku udává, že tento spotřebič nepatří do domácího odpadu. Spotřebič je nutné odvézt do sběrného místa pro recyklaci elektrického a elektronického zařízení.

Likvidace musí být provedena v souladu s místními předpisy o ochraně životního prostředí, které se týkají likvidace odpadu. Podrobnější informace o zpracování, recuperaci a recyklaci tohoto výrobku zjistíte u příslušného místního úřadu, služby pro likvidaci domovního odpadu nebo v obchodě, kde jste výrobek zakoupili.

SK Tento spotřebič je označen v súlade s Európskou smernicou 2002/96/ES o likvidácii elektrických a elektronických zariadení (WEEE). Zabezpečením, že tento výrobok bude zlikvidovaný správnym spôsobom, pomôžete predchádzať potenciálnym negatívnym dopadom na životné prostredie a ľudské zdravie, ktoré by sa v inom prípade mohli vyskytnúť pri nevhodnom zaobchádzaní pri likvidácii tohto výrobku.

Symbol  na výrobku alebo na sprievodných dokumentoch znamená, že s týmto výrobkom sa nesmie zaobchádzať ako s domovým odpadom. Naopak, treba ho odovzdať v zberom stredisku na recykláciu elektrických alebo elektronických zariadení. Likvidácia musí byť vykonaná v súlade s predpismi na ochranu životného prostredia pre likvidáciu odpadov.

Podrobnejšie informácie o zaobchádzaní, regenerácii a recyklácii tohto výrobku si vyžiadajte na Vašom miestnom úrade, v zberných surovinách alebo v obchode, kde ste výrobok kúpili.

H A készüléken található jelzés megfelel az elektromos és elektronikus berendezések hulladékairól szóló 2002/96/EK európai irányelvben (WEEE) foglalt előírásoknak.

A hulladékká vált termék szabályszerű elhelyezésével Ön segít elkerülni a környezettel és az emberi egészséggel kapcsolatos azon esetleges negatív következményeket, amelyeket a termék nem megfelelő hulladékkezelése egyébként okozhatna.

A terméken vagy a termékhez mellékelte dokumentumokon feltüntetett

jelzés arra utal, hogy ez a termék nem kezelhető háztartási hulladékként. Ehelyett a terméket a villamos és elektronikus berendezések újrahasznosítását végző telephelyek valamelyikén kell leadni.

Kiselejtezőskor a hulladékéltávolításra vonatkozó helyi környezetvédelmi előírások szerint kell eljárni.

A termék kezelésével, hasznosításával és újrahasznosításával kapcsolatos bővebb tájékoztatásért forduljon a lakóhelye szerinti polgármesteri hivatalhoz, a háztartási hulladékok kezelését végző társasághoz vagy ahhoz a bolthoz, ahol a terméket vásárolta.

RUS Данное изделие промаркировано в соответствии с Европейской директивой 2002/96/EC по утилизации электрического и электронного оборудования (WEEE).

Обеспечив правильную утилизацию данного изделия, Вы можете предотвратить потенциальные негативные последствия для окружающей среды и здоровья человека, которые могли бы иметь место в противном случае.

Символ  на самом изделии или сопроводительной документации указывает, что при утилизации данного изделия с ним нельзя обращаться как с обычными бытовыми отходами. Вместо этого, его следует сдавать в соответствующий пункт приемки электрического и электронного оборудования для последующей утилизации.

Сдача на слом должна производиться в соответствии с местными правилами по утилизации отходов. За более подробной информацией о правилах обращения с такими изделиями, их утилизации и переработки обращайтесь в местные органы власти, в службу по утилизации отходов или в магазин, в котором Вы приобрели данное изделие.

BG Този уред е маркиран в съответствие с Европейска директива 2002/96/EO "Електрическо и електронно оборудване за отпадъци" (WEEE).

Като се погрижите това изделие да бъде изхвърлено по правилен начин, вие ще помогнете за предотвратяване на възможните негативни последици за околната среда и здравето на хората, което в противен случай може да бъде предизвикано от неправилно изхвърляне на това изделие.

Символът  върху изделието или върху документите, приложени към изделието, показва, че това изделие не бива да се третира като битови отпадъци. Вместо това, то трябва да се предава в специализиран пункт за рециклиране на електрическо и електронно оборудване.

При изхвърлянето му спазвайте местните норми за изхвърляне на отпадъци.

За по-подробна информация за третирането, възстановяването и рециклирането на това изделие се обърнете към вашата местна градска управа, към вашата служба за изхвърляне на битови отпадъци или към магазина, откъдето сте закупили изделието.

RO Acest aparat este marcat în conformitate cu Directiva Europeană 2002/96/CE referitoare la Deșeurile de Echipament Electric și Electronic (WEEE). Asigurându-vă că acest produs este eliminat în mod corect, contribuiți la prevenirea potențialelor consecințe negative asupra mediului înconjurător și sănătății persoanelor, consecințe care ar putea fi provocate de aruncarea necorespunzătoare la gunoi a acestui produs.

Simbolul  de pe produs, sau de pe documentele care însoțesc produsul, indică faptul că acesta nu poate fi aruncat împreună cu deșeurile menajere. Trebuie predat la punctul de colectare corespunzător, pentru reciclarea echipamentului electric și electronic.

Aruncarea la gunoi a aparatului trebuie făcută în conformitate cu normele locale pentru eliminarea deșeurilor. Pentru informații mai detaliate privind eliminarea, valorificarea și reciclarea acestui produs, vă rugăm să contactați administrația locală, serviciul de eliminare a deșeurilor menajere sau magazinul de unde ați cumpărat produsul.