

PRAKTISCH/PRACTICAL

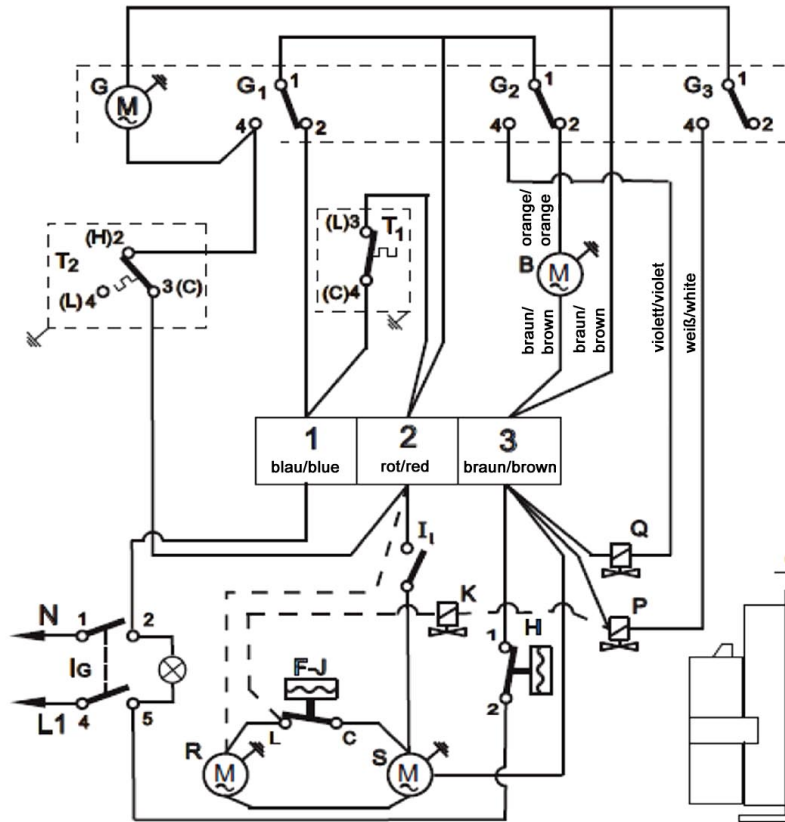

Zeitschaltuhr / timer

THEORETISCH/THEORETICAL

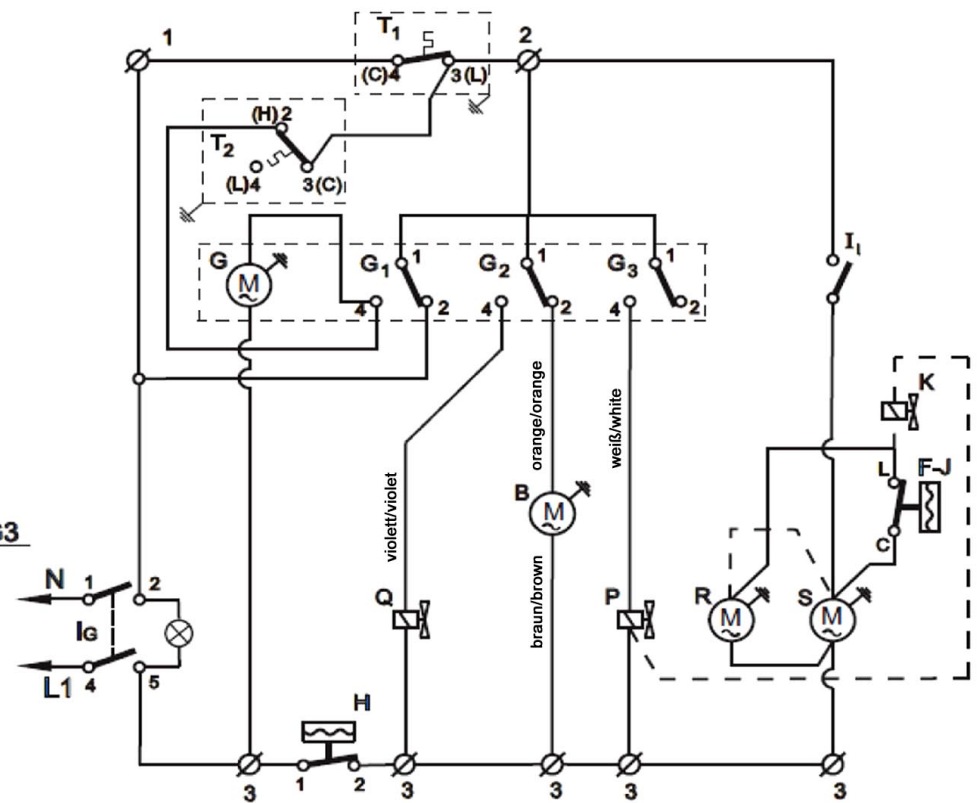

Bauteile / components:

- | | |
|--|---|
| <p>B Motorpumpe / motor pump
 F Lüfterpressostat (Luft) / fan pressure switch
 G Nocken-Zeitschalter / lobe-timer
 G1 Sicherheits-Zeitschalter für Kreislauf / safety-timer for circuit
 G2 Kreislauf-Zeitschalter / circuit-timer
 G3 Kreislauf-Zeitschalter (Wassereinlassventil /Sicherheitspressostat) / circuit-timer (water inlet valve / safety pressure switch)
 J Kondensations-Pressostat (Wasser) / condensation-pressure switch (water)
 K Kondensations-Magnetventil (Wasser) / condensation-soleniod valve</p> | <p>P Wassereinlassventil / water inlet valve
 Q Heißgas-Magnetventil / hotgas-solenoid valve
 R Lüftermotor / fan motor
 S Kompressor / compressor
 T1 Speicherthermostat / storage thermostat
 T2 Kreislaufthermostat / circuit thermostat
 Ig EIN- / AUS-Schalter / on/off switch
 II Reinigungsschalter für Wasserkondensator / clean-switch for water-condenser</p> |
|--|---|